

1

-7

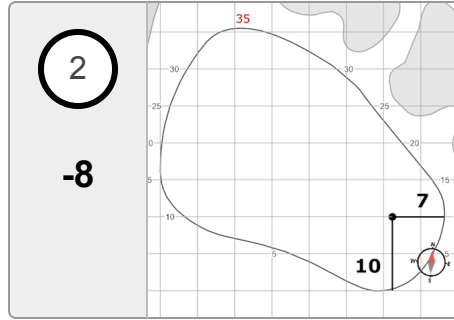

2

-8

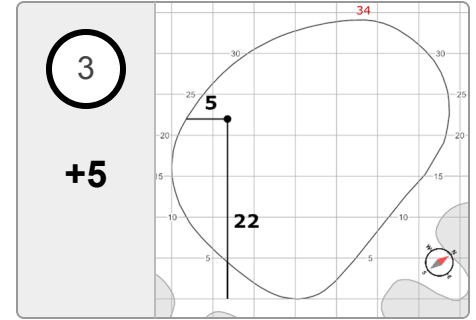

3

+5

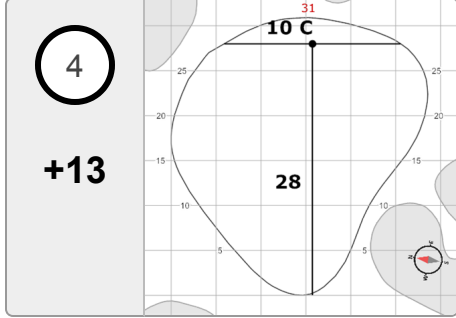

4

+13

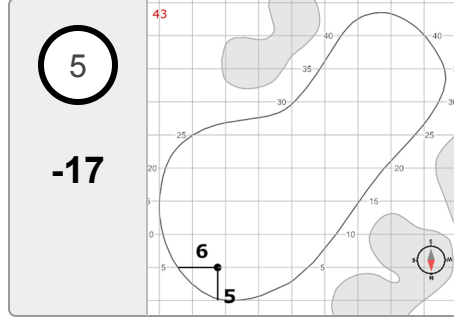

5

-17

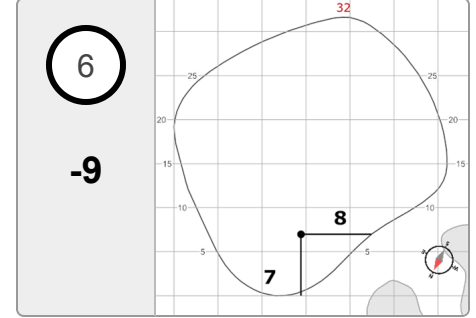

6

-9

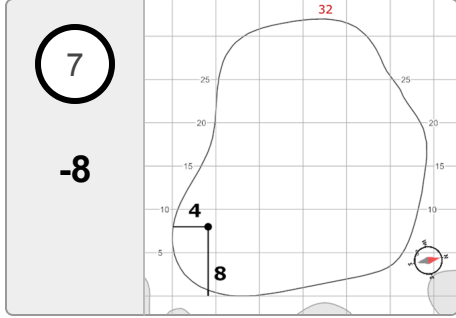

7

-8

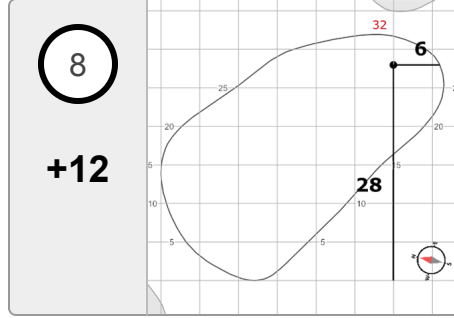

8

+12

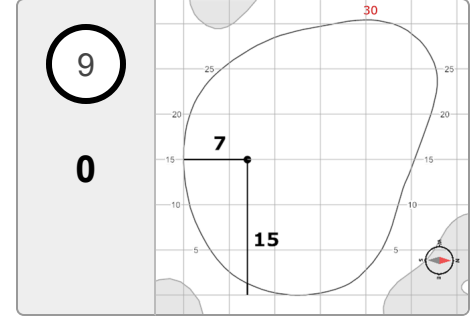

9

0

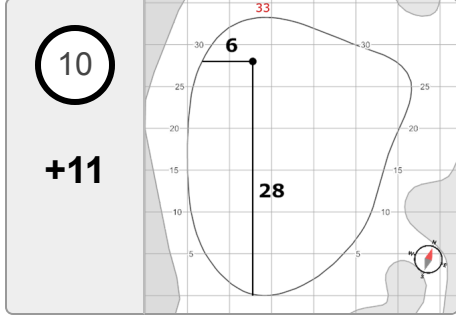

10

+11

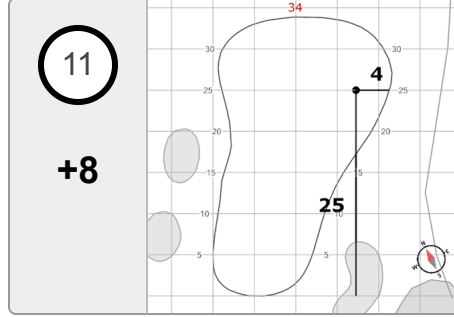

11

+8

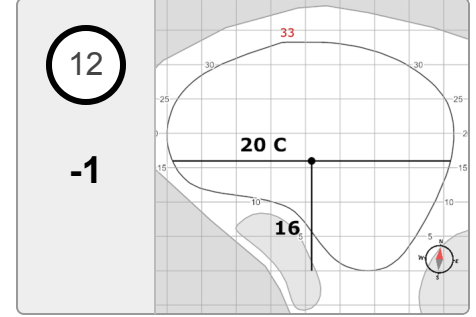

12

-1

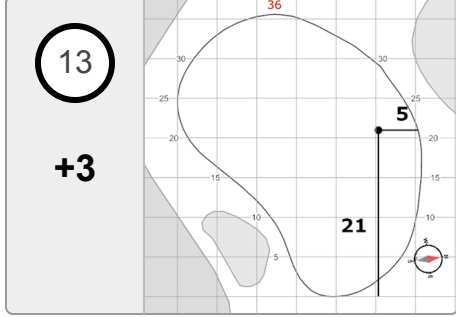

13

+3

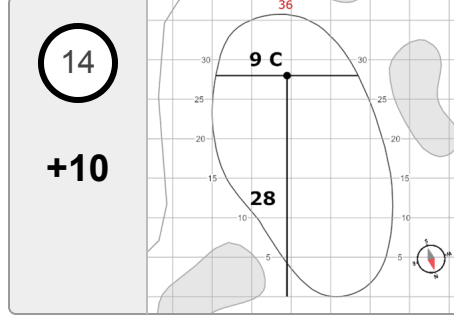

14

+10

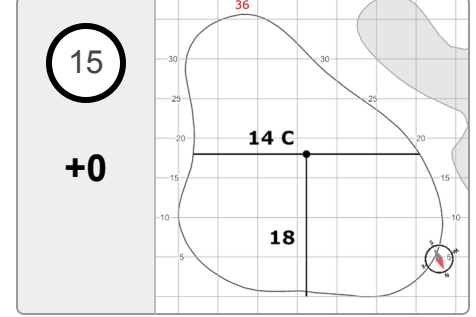

15

+0

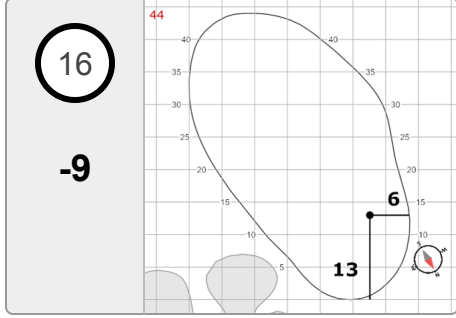

16

-9

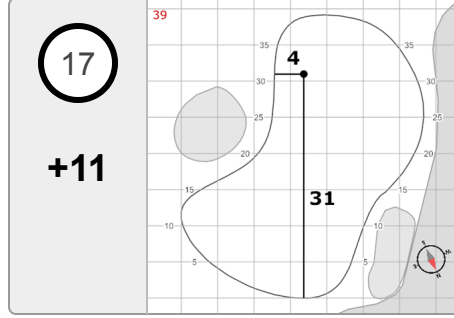

17

+11

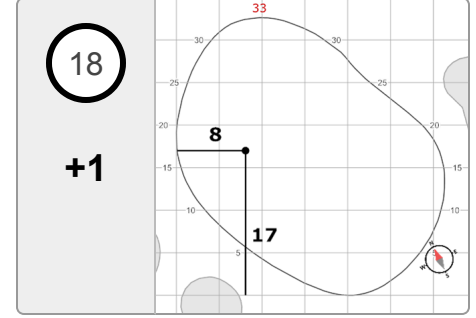

18

+1